



Pilot Operated Check Valve Instruction Manual

MODEL: CVP3

SFA Companies 10939 N. Pomona Ave. Kansas City, MO 64153
Tel: 888-332-6419 * Fax: 816-448-2142
E-mail: sales@bvahydraulics.com Website: www.bvahydraulics.com

Maximum Operating Pressure 10,000 PSI

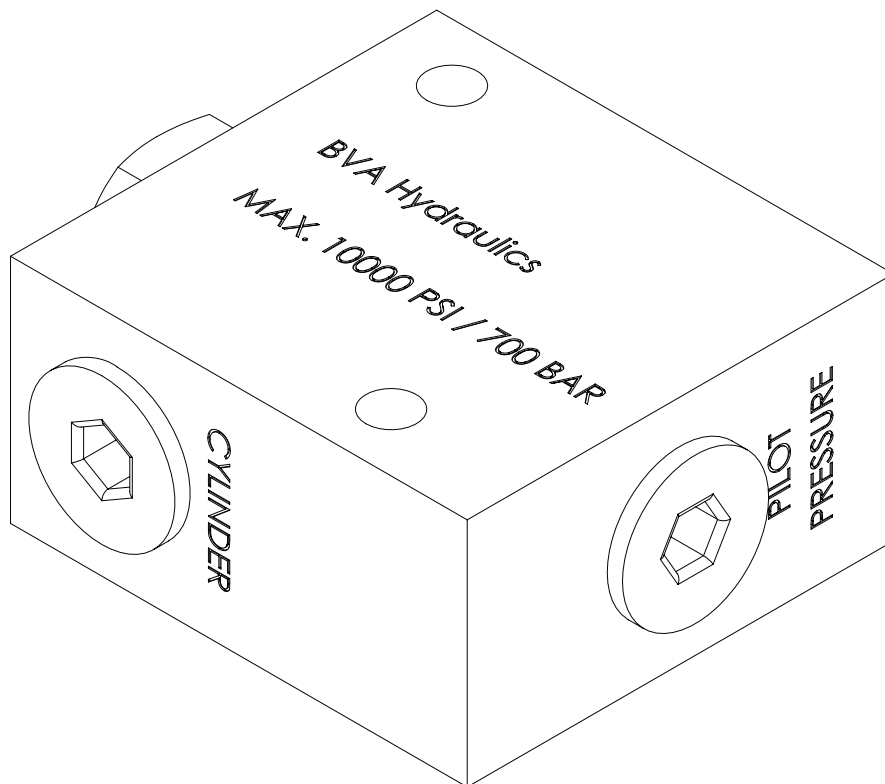

This is the safety alert symbol. It is used to alert you to potential personal injury hazards. Obey all safety messages that follow this symbol to avoid possible injury or death.

SAFETY AND GENERAL INFORMATION

Save these instructions. For your safety, read and understand the information contained within. The owner and operator shall have an understanding of this product and safe operating procedures before attempting to use this product. Instructions and safety information shall be conveyed in the operator's native language before use of this product is authorized. Make certain that the operator thoroughly understands the inherent dangers associated with the use and misuse of the product. If any doubt exists as to the safe and proper use of this product as outlined in this factory authorized manual, remove from service immediately.

Inspect before each use. Do not use if leaking, broken, bent, cracked or otherwise damaged parts are noted. If the valve has been or suspected to have been damaged, discontinue use until checked out by a BVA Hydraulics authorized service center. Owners and operators of this equipment shall be aware that the use and subsequent repair of this equipment may require special training and knowledge. It is recommended that an annual inspection be done by qualified personnel and that any missing or damaged parts, decals, warning/safety labels or signs be replaced with BVA Hydraulics authorized replacement parts only. Any check valve that appears to be damaged in any way, is worn or operates abnormally shall be removed from service immediately until such time as repairs can be made.

PRODUCT DESCRIPTION

BVA Hydraulics Pilot Operated Check Valve is used to sustain a load in the event of a loss of hydraulic system pressure. A wide variety of applications exist for this category of product. Special skill, knowledge and training may be required for a specific task and the product may not be suitable for all the jobs described above. The user ultimately must make the decision regarding suitability of the product for any given task and therefore accept responsibility for that decision.

⚠ WARNING: Always wear proper personal protective gear when operating hydraulic equipment (i.e. safety glasses, gloves, etc.)

⚠ CAUTION: Always check connections before using. Alteration of these products is strictly prohibited. Use only those equipment and attachments provided and approved by the manufacturer.

⚠ WARNING: To reduce the risk of personal injury and/or property damage, ensure that the rated working pressure of each pressurized attachment be equal to or greater than the rated working pressure developed by the hydraulic pump.

SPECIFICATIONS

Model Number	Operating Pressure (psi)	Coupler Size	Length (in)	Width (in)	Height (in)	Weight (lbs)	Pressure Switch Adjustability (psi)
CVP3	0 - 10000	3/8-18 NPTF	3.48	2.95	1.50	3.22	1,000 - 10,150

INSTALLATION AND ADJUSTMENT

CONNECTING TO THE HYDRAULIC SYSTEM

Reference illustration at right for valve configuration. The Pilot Operated Check Valve ports are labeled "Pump," "Cylinder," and "Pilot Pressure."

- 1) Remove thread plugs and connect Check Valve "Pilot Pressure" and "Pump" ports to pump.
- 2) Connect "Cylinder" port to load.
- 3) If the pump is double-acting ("A" and "B" ports), connect "Pump" port to "A" port on pump, and "Cylinder" port to "A" port on cylinder via 3/8-18 NPTF nipple (not included, ref. Figure 2).
- 4) Connect cylinder "B" port to "Pilot Pressure Port" on valve and to "B" port on pump via an inline T-fitting and 3/8-18NPTF nipple (not included).

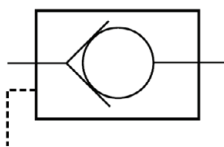

Figure 1 - Switch is wired normally open and held closed by spring force.

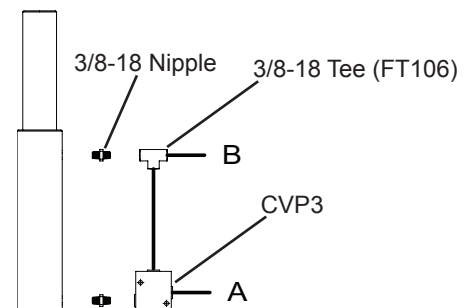
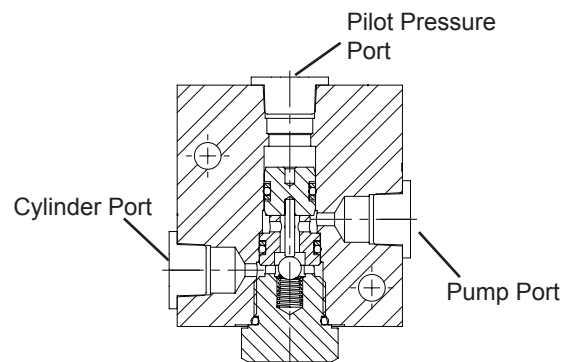

Figure 2 - Double-acting cylinder configuration.

⚠ WARNING



Failure to comply with the following warnings may result in **personal injury** as well as **property damage**.



Study, understand, and follow all instructions provided with and on this device before use. The user must be a qualified operator familiar with the correct operation, maintenance, and use of cylinders.



Wear protective gear when operating hydraulic equipment.



Crush Hazard. Keep hands and feet away from cylinder and workpiece during operation.



Do not exceed rated capacity of any equipment in the system. The check valve is designed for a max. pressure of 10,000 psi. Do not connect to a pump with higher pressure rating.



The system operating pressure must not exceed the pressure rating of the lowest rated component the system. Install a pressure gauge or other load measuring instrument to monitor the operating pressure. Burst hazard exists if hose, connection or any other component in the system exceed its rated pressure.



Hydraulic fluid can ignite and burn. Keep hydraulic equipment away from flames and heat. Excessive heat will soften seals, resulting in fluid leaks. Heat also weakens hose materials.



Never try to disassemble check valve. Refer repairs to qualified, authorized personnel. Contact BVA Hydraulics tech service for authorized service center.



- No alteration shall be made to the valve.
- Use only factory authorized fasteners, accessories and hydraulic fluid.

LIMITED LIFETIME WARRANTY

BVA Hydraulics®, represented in the United States by SFA Companies ["SFA"] warrants this product to be free from defects in material and workmanship for the life of the product as long as the original purchaser owns the product. The warranty is non-transferable and is subject to the terms, exclusions, and limitations described below:

- Damaged components, including but not limited to bent rams, dented or crushed cylinder walls, broken welds or couplers as well as worn out seals, o-rings and springs are the result of misuse and not covered by warranty and BVA Hydraulics will not provide any warranty credit for such damaged components.
- This warranty does not cover ordinary wear and tear, overloading, alterations (including repairs or attempted repairs not performed by BVA Hydraulics or one of its authorized personnel), improper fluid use, or use of the product in any manner for which the product was not intended or the use of which is not in accordance with the instructions or warnings provided with the product.
- In the unlikely event that a BVA Hydraulics product fails due to material defect in workmanship, you may contact SFA for disposition. In such cases, the customer's sole and exclusive remedy for any breach or alleged breach of warranty is limited to the repair or replacement of the defective product.
- Under no circumstances is BVA Hydraulics liable for any consequential or incidental damage or loss whatsoever.
- THIS WARRANTY IS LIMITED TO NEW PRODUCTS SOLD THROUGH AUTHORIZED DISTRIBUTORS AND OTHER CHANNELS DESIGNATED BY BVA HYDRAULICS. NO AGENT, EMPLOYEE OR OTHER REPRESENTATIVE OF BVA HYDRAULICS IS AUTHORIZED TO MODIFY THIS WARRANTY.
- THE FOREGOING IS EXCLUSIVE AND IS IN LIEU OF ALL OTHER EXPRESS AND IMPLIED WARRANTIES, INCLUDING BUT NOT LIMITED TO THE IMPLIED WARRANTIES OF MERCHANTABILITY AND FOR A FITNESS FOR A PARTICULAR PURPOSE.
- Components not manufactured by BVA Hydraulics including certain motor systems, gasoline engines, and other are not covered by this warranty and instead are covered by the manufacturer's separate manufacturer's warranty provided in the package.
- BVA Hydraulics' liability in all cases is limited to, and will not exceed the purchase price paid for the product.



Pilot Operated Check Valve Service Parts

MODEL: CVP3

SFA Companies 10939 N. Pomona Ave. Kansas City, MO 64153
 Tel: 888-332-6419 * Fax: 816-448-2142
 E-mail: sales@bvahydraulics.com Website: www.bvahydraulics.com

Note: Not all components of the cylinder are replacement items, but are illustrated as a convenient reference of location and position in the assembly sequence. To ensure safe and reliable performance, replace worn or damaged parts with BVA authorized repair parts only.

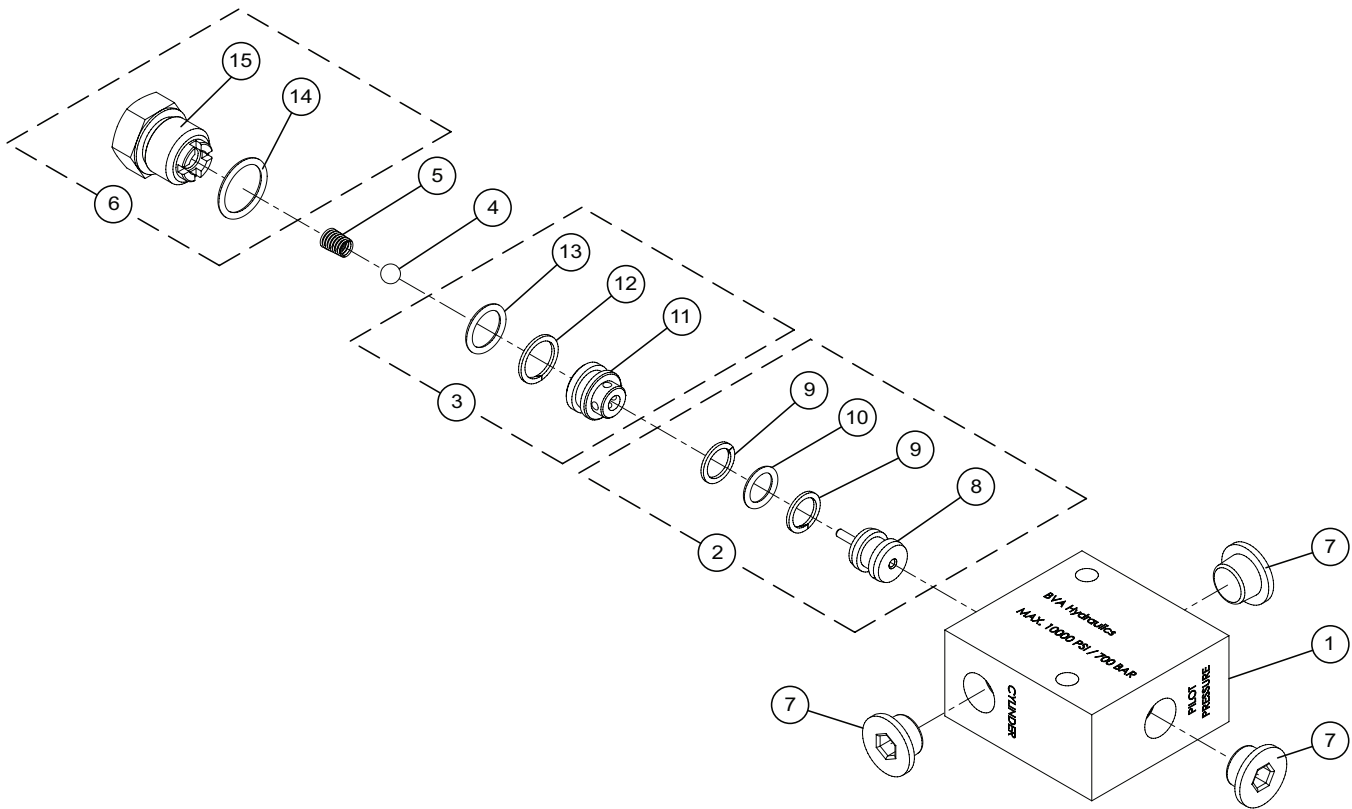

Item	Part No.	Description	Qty.
1	N/A	Valve Body	1
2	D09-4-1013-109	Piston Assembly	1
-8	N/A	Piston Assembly	1
-9	*	Back-Up Ring	2
-10	*	O-Ring	1
3	D09-4-1002-104	Seat Assembly	1
-11	N/A	Seat	1
-12	*	Back-Up Ring	1
-13	*	O-Ring	1

Item	Part No.	Description	Qty.
4	*	Steel Ball	1
5	*	Spring	1
6	D09-4-1001-102	Spring Guide Assembly	1
-14	*	O-Ring	1
-15	N/A	Spring Guide	1
7	A57-6-5002-105	Oil Port Plug	3
*	D07-3-9905-106	Valve Assembly Repair Kit	1